

Substation Familiarisation



Contents

Contents
Preface
Section 1 – Purpose of a Substation
Substation Configurations
Section 2 – Substation Components and their purposes.
Circuit Breakers
Disconnectors
Transformers

Substation Familiarisation

Preface

The Purpose of this document is to introduce the concept of the Substation to the reader, including the components that make up a Substation (including devices used for Protection purposes) and the different types of Substation that can be found within the most of the countries. This document is fully referenced throughout and for further details beyond the scope of this document, the reader is encouraged to look therein.

Note that this document is restricted to the equipment, methods and designs currently in use within National Grid Transco, and that it is a familiarisation document, not designed to look at any particular system in great detail.

Also mentioned in this document are the Rules and Regulations required for working in Substations.

1. The Purpose of a Substation

Ultimately, a Substation, regardless of design or location is for the following purposes:

1. To provide a termination point for Overhead Lines.
2. To provide a transformation facility whereby the incoming voltage (which is typically 400kV from the Overhead Lines, although this could vary dependent on location, Substation type and circuits into/out of the Substation) can be transformed to a higher or lower Voltage.
3. To provide a point of interface to the National Grid for Generating companies.
4. To provide a point of interface for the distribution networks to receive their electricity supplies so that they may distribute it to their customers.
5. To provide a location where Network protection and maintenance can be carried out by National Grid Transco employees.

How these five points are achieved will vary from Substation to Substation dependent of their locations, circuits, Voltages and the equipment that they contain. Furthermore, some substations may have dedicated tasks instead or as well as the tasks mentioned above.

There are 2 different types of substation, which are reflected by the types of switchgear that they use. These are Air Insulated Switchgear Substations (AIS Substations) and Gas Insulated Switchgear Substations (GIS Substations). Both of these types can be either outdoor or indoor. Currently, the most common type is the AIS Substation, which accounts for approximately 75% of all Substations in the UK. In terms of functionality, there are no fundamental differences between the types in that they are all designed to carry out all or some of the purposes described above. Below is a table of advantages and disadvantages of both types of substations.

AIS Substations	GIS Substations
Cheaper than GIS.	More Costly than AIS.
Require large areas.	Compact Design.
Can be exposed to pollution (for example Salt Water) if outdoors.	Normally housed indoors.
Environmentally friendly in comparison to GIS	GIS Substations use a lot of SF ₆ , which can have an impact on the environment.
Easy to extend or modify.	Can be difficult to extend or modify unless this has been pre-designed.
Complex to replace assets.	Asset replacement comparatively easier.

Both types of substations typically have buildings for the equipment (if it is an indoor substation), and/or buildings around the equipment for offices and other purposes for staff (e.g.: mess halls, drawing rooms and storage facilities). These will not be covered in this document.

Also, beyond these two types, there are seven different configurations for each type, which are Switched 'Tee', Single Switch or H-type arrangement, Three Switch with Bypass, Single Busbar, Mesh or Ring Bus, Double Busbar and Breaker and a half

configurations. Each of these configurations has their own advantages and disadvantages, which will be highlighted.

1.1 Switched ‘Tee’ Configuration

A simple diagram of the switched ‘tee’ configuration is shown below, along with a table of advantages and disadvantages.

Advantages	Disadvantages
Simple design.	Requires circuit outage to isolate transformer.
Economical.	Requires intertripping for transformer faults.

1.2 Single Switch Station (or H-type arrangement)

This configuration is shown in schematic form below, along with a table of advantages and disadvantages.

Advantages	Disadvantages
Economical on Circuit Breakers.	Requires intertripping for transformer faults.
Easy to build.	May give rise to ferroresonance.

1.3 Three Switch with Bypass

This is shown below, with a table of advantages and disadvantages of this configuration.

Advantages	Disadvantages
Economical.	Circuit Breaker fail on section switch causes a loss of all supplies.
Flexible.	
Transformers can be switched out for maintenance without interruption of the line.	

1.4 Single Busbar

This is shown below, with a table of the advantages and disadvantages of the configuration.

Advantages	Disadvantages
Simple design.	Busbar maintenance requires a large number of circuits to be switched out.
Economical.	Inflexible.
Allows sectionalising on bus section breaker.	Maintenance of Circuit Breaker requires circuit to be out of service.

1.5 Four Switch Mesh (Or Ring Bus)

This configuration is shown below, along with a table of advantages and disadvantages.

Advantages	Disadvantages
Economical.	Limited Flexibility for sectionalising
After clearance of feeder faults, Circuit Breakers can be closed to complete the mesh.	May give rise to ferroresonance
Circuit Breaker maintenance can be carried out without loss of supply.	Not easy to extend.
	Requires complex intertripping and autoreclose systems.

1.6 Double Busbar

This configuration is shown below, with a table showing the advantages and disadvantages of the system.

Advantages	Disadvantages
Allows sectionalising on bus section and bus coupler breakers.	Maintenance of Circuit Breaker requires the circuit to be out of service.
Flexible.	Busbar fault will lose some circuits until substation can be reconfigured.
Circuits can be transferred on load.	Bus Section or Bus Coupler Circuit Breaker faults will lose two sections of bus bar.
Any single section of busbar can be maintained without loss of circuits.	

1.7 Breaker and a half

This configuration is shown below, along with a table of advantages and disadvantages.

Advantages	Disadvantages
Maintenance of Circuit Breaker does not require circuit out of service.	Expensive – each circuit requires 1½ circuit breakers.
Busbar faults do not lose any circuits during faults.	Not so flexible for sectionalising for short circuit control or grouping of circuits for load flow.
Provides bus coupling at every diameter.	Requires more circuit breakers to open to clear faults.
Either busbar can be maintained without loss of circuits.	

2. Principal Components of a Substation and their purposes

As previously mentioned, substations are entities comprising of several components. This document will look at each in detail.

The following table lists some of the major components of a substation and is a list of components that this article will examine in detail.

Circuit Breakers (CBs)
Disconnectors
Transformers
Earth Switches
Instrument Transformers (CTs, VTs and CVTs)
Busbars
Cables and Cable Sealing Ends
Capacitor Banks
Synchronous Compensators
RSVCs
SVCs
Battery Systems
Compressed Air Systems
Diesel Generators
Low Voltage (LV) Equipment
Protection and Protection Signalling Systems
Substation Control Systems

2.1 Circuit Breakers (CBs)

There are many different Circuit Breakers in use on the Supergrid today which can be chiefly broken down into three main types – Oil Circuit Breakers (OCBs), Air Blast Circuit Breakers (ABCBs) and Sulphur Hexafluoride Circuit Breakers (SF₆CBs). Their purpose is to provide a physical disconnection or connection in times of faulty or normal operating conditions respectively. Furthermore, they must be able to handle such switching under full load conditions.

Principally, Circuit Breakers of any type are designed to break a circuit at zero current – which is when the AC current passes through a zero point. Extinguishing of the arc is done on a lengthening and cooling of the arc basis and any by-products of this are to be evacuated rapidly and efficiently.

2.1.1 Oil Circuit Breakers (OCBs)

Oil circuit breakers can be broken down into two subtypes – Bulk and Minimal oil, with the only significant difference being the volume of oil being present. In such Circuit Breakers, the oil acts as both the insulator and the quenching medium for the arc that is drawn upon opening the breaker. The arc possesses enough energy for the oil to be broken down into Hydrogen and Carbon and it is the Hydrogen gas that

extinguishes the arc by conducting the heat into the cooler surrounding oil, and the Carbon remains behind, as a contaminant in the oil. Thus, after a certain amount of uses, the oil must be changed as the insulating property of the oil is changed (the Carbon left behind is conductive).

After the arc has been extinguished, by separation of the contacts and the movement of cool oil, the gaseous by-products escape through vents, or else the pressure may increase in the Circuit Breaker chamber to a point where it may rupture or explode. Further care must be taken with OCBs that may include the construction of fire/blast walls when first installed.

The following diagram and picture show an overall schematic and a photographic view of an OCB respectively.

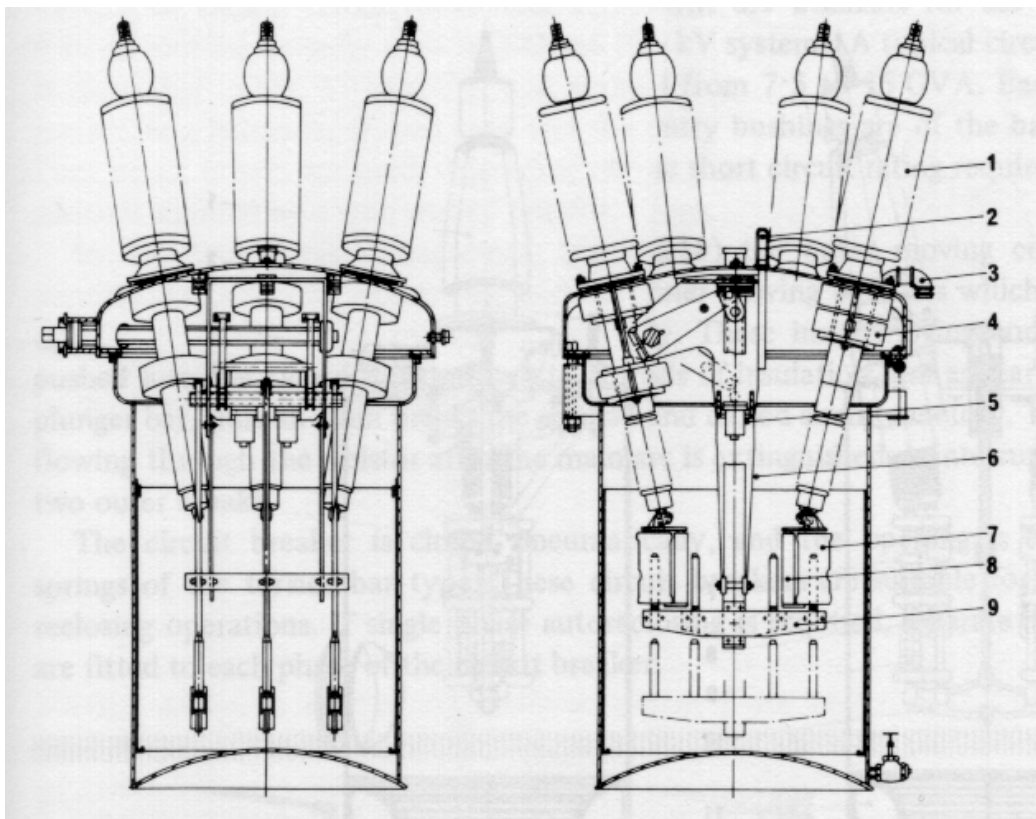

Diagram showing a schematic of an Oil Circuit Breaker. Key follows:

1 Bushing	6 Plunger Guide
2 Oil Level Indicator	7 Arc Control Device
3 Vent	8 Resistor
4 Current transformer	9 Plunger Bar
5 Dashpot	

Picture of an Oil Circuit Breaker.

2.1.2 Air Blast Circuit Breakers (ABCBs)

Air Blast Circuit Breakers work by cooling the arc with high-pressure air when the contactors are separated. As the air passes into the chamber, which is done at high pressure, the speed reaches sonic levels (and this can be attributed to the loud noise that is heard when an ABCB operates) which cools down the arc, and carries the heat out to atmosphere. At zero current in the cycle, the arc is extended and cooled to a point where it is extinguished. The air used in these circuit breakers comes from the compressors, which are located on site.

When dealing with ABCBs, great care must be taken to ensure that people in the vicinity are either a large distance away from the circuit breaker, or that they are wearing Ear Protection, as the sound of an ABCB can reach painful levels, and can even cause deafness.

The following diagram and picture shows a schematic of an ABCB and an ABCB at Keadby 400kV Substation.

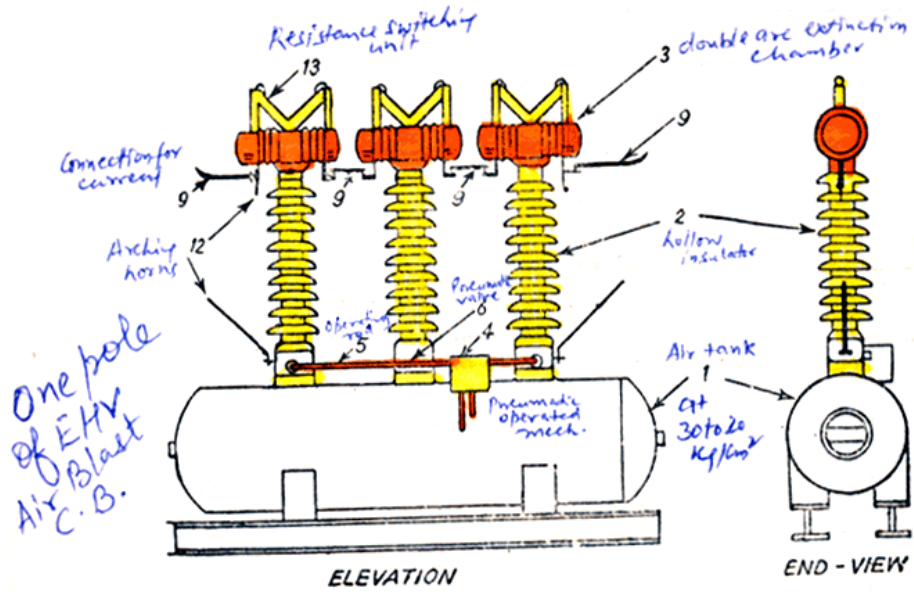

One pole of an extra-high voltage air blast circuit-breaker.

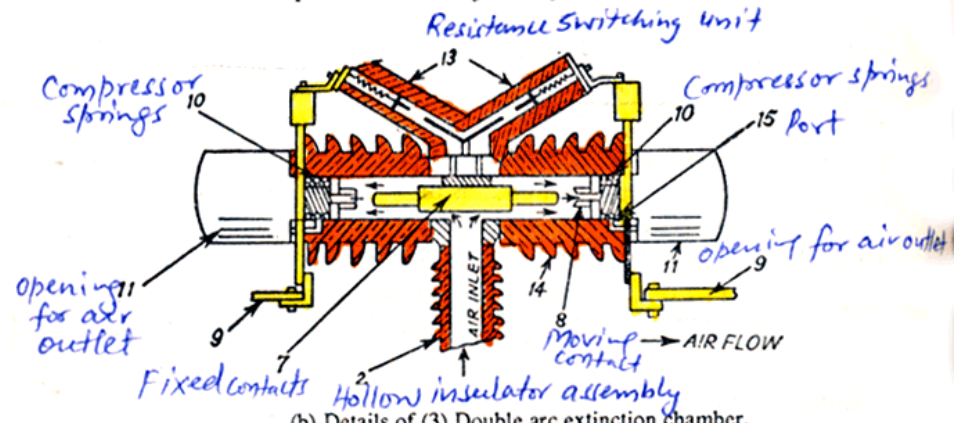

Schematic of an ABCB.

2.1.3 Sulphur Hexafluoride (SF₆) Circuit Breakers

An SF₆ circuit breaker works in a similar way to the Air Blast Circuit Breaker, in that there is a flow of gas that cools down the arc. However, this gas, once used is not vented out in the same way as the air in the ABCB, as the gas has by-products that are considered to be harmful to the environment.

SF₆ has approximately twice the electrical strength as normal air, and is also electronegative – this means that the free electrons in the arc (which is all that an arc is) can be absorbed by the molecules in the gas. The result of this is that there is an increase in the dielectric strength after zero current.

When the contacts are forced apart (that is, when the breaker is in the process of opening), High pressure SF₆ gas flows into the chamber from a reservoir (maintained by Compressors) or via a piston mechanism that produces ‘puffs’ of gas (this is known as the ‘puffer mechanism’).

It should be warned that the break down products are very dangerous, particularly Sulphur Dioxide and Hydrofluoric Acid, for which disposal has to be done in a particular manner.

The following table¹ lists some of the Physical and Chemical properties of Sulphur Hexafluoride:

Appearance	Pressurised Liquefied Gas
Colour	Colourless
Odour	Odourless
Melting Point	-50.8°C
Boiling Point	-63.8°C
Remark	Sublimation
Flash Point	N/A
Flammability	N/A
Auto-Flammability	N/A
Vapour Pressure	21.4 Bar at 20°C 37.1 Bar at 45°C
Density	1.56 at 0°C
Specific Density	6.16 in gaseous form
Vapour Density Relative to Air	5.1
Soluble in	Water (40mg/l) at 20°C Alcohol Ether
pH	Neutral
Decomposition Temperature	200°C (Moist Air) 800°C (Dry Air)
Danger of Explosion	N/A
Oxidising Properties	N/A

The following diagram shows a schematic of an SF6 Circuit Breaker and the picture shown is of an SF6 breaker at Killingholme 400kV Substation.

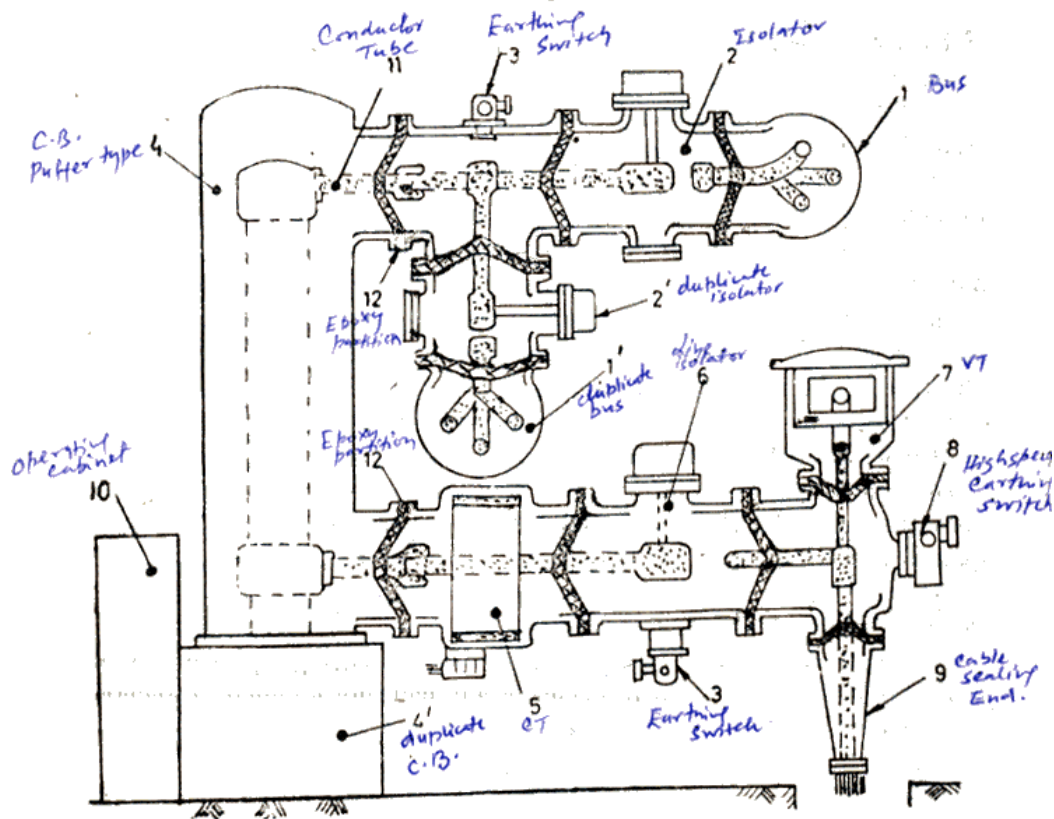

Schematic of a SF₆ CB.

2.1.5 Summary of Circuit Breakers

A brief table outlining of each type of circuit breaker.

Circuit Breaker Type
OCB
ABCB
SF ₆ CB

2.2 Disconnectors

Disconnectors are similar in purpose to Circuit Breakers, except that they are not designed to make or break fault current, load current or transformer magnetising current. They can be used in the charging/discharging of sections of Busbars or, in multiple Busbar systems, they can be used as mechanisms for selection.

More importantly, however, is that they serve primarily as a point of isolation when maintenance work is taking place.

There are three main types of disconnectors – Air Insulated, GIS and Pantograph. With all of these, Earth Switches may be present, either one side of the disconnector or both sides, which will be discussed later.

2.2.1 Air Insulated Disconnectors

These disconnectors are the most common in National Grid. They consist of a centre post and a contact, which can rotate 90 degrees to form/break a contact. Such systems can be either hand or motor operated. There are variations on this basic design, but the principles remain the same. The following diagram and photo show a schematic and a 400kV Disconnector as found at a Substation.

2.2.2 GIS Disconnectors

These are used at a Substation that uses SF6 and work in a similar manner to the SF6 Circuit Breaker, as described in section 2.1.3. The diagram shows a schematic of such a device and the photo is of one at a Substation.

2.2.3 Pantograph Disconnectors

This is the most up to date design of disconnectors and is especially used where space is at a premium. They work in the vertical plane and clamp onto Busbars that are directly above it. These are motor operated and usually have an incorporated Earth Switch with them. The diagram shows a schematic of a Pantograph and the photo shows one in use.

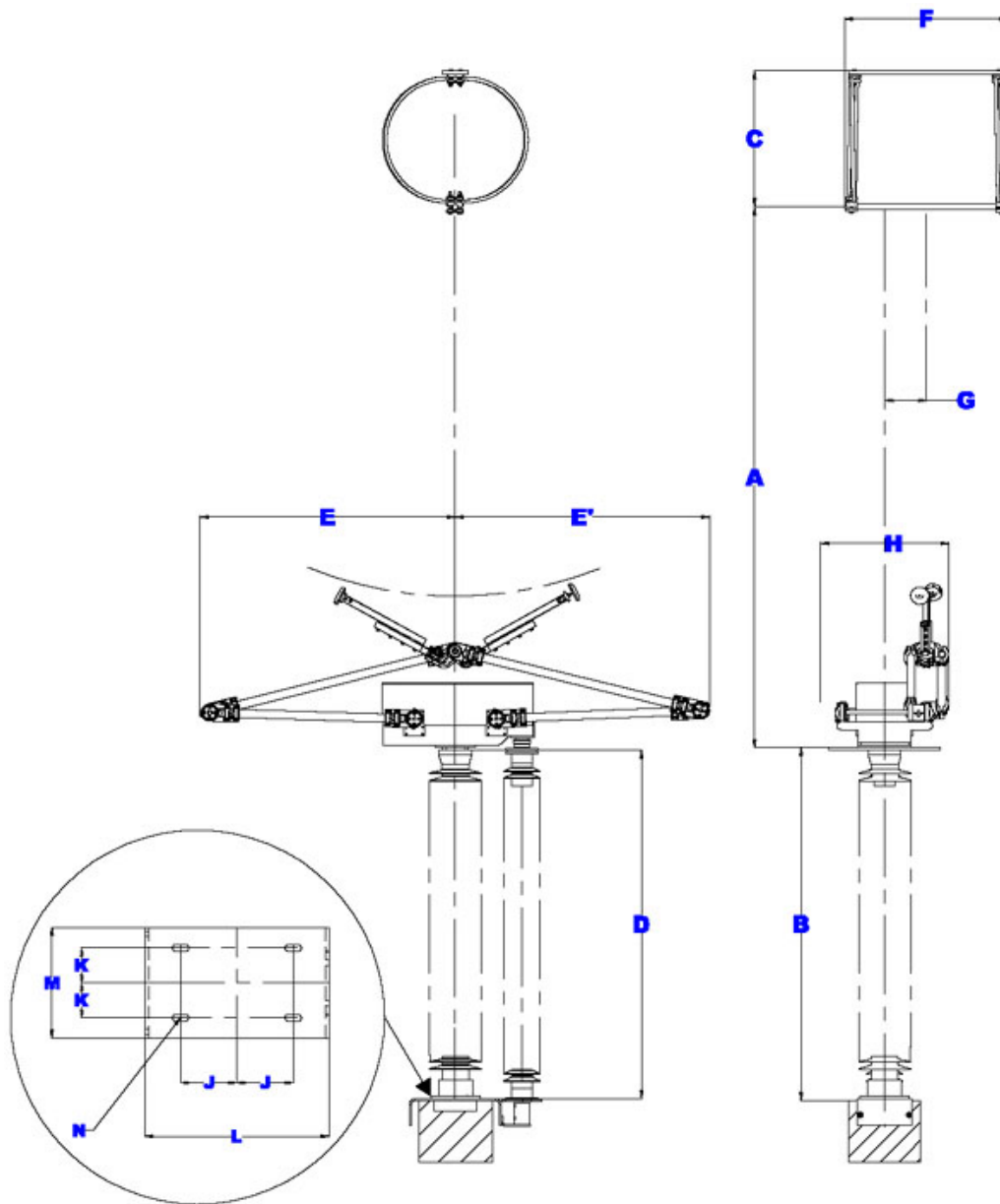

Schematic of a Pantograph disconnector.



Example of a Pantograph Disconnecter.

2.3 Transformers

Transformers are typically of two types – Air Cooled and Oil Cooled, of which either can be forced or naturally cooled. The difference between forced and naturally cooled is that the MVA rating of naturally cooled transformers, regardless of type is 50% lower of the forced cooled. These are thus referred to as ONAN ONAF OFAN and OFAF (Oil Natural Air Natural, Oil Natural Air Forced, Oil Forced Air Natural and Oil Forced Air Forced) where pumps are used to pump the oil and fans are used to force the air.

There are also different winding types for each transformer, dependent on the purpose the transformer is being used for – Two Winding, Three Winding, Auto Transformers and Earthing Transformers.

Also included in transformers is a tap changing facility, which is used primarily for maintaining the voltage across the system. In this article, Two Winding transformers and Earthing transformers will not be covered.

The basic operating principle of Transformers does not change from the basic principles laid down at schooling level. Transformers have, in principle, two sides –

Primary and Secondary, where the Primary is often the incoming circuit and the Secondary is the outgoing circuit (although the deviations from the basic, such as the inclusion of a Tertiary Winding is outlined below) and control of these sections indicates control of the rating of the circuit in general.

Inside a typical transformer there is a core (made of Iron for best performance, and to reduce losses and inefficiency) around one side is the Primary Winding and the other is the Secondary Winding. The windings consist of turns of wire and when the Primary circuit is active, a magnetic field is generated which induces a current in the Secondary circuit, through the Secondary winding. The relationships between the windings dictate the conditions of the transformer (that is, whether the transformer steps up or steps down the voltage), and the equations that dictate the relationships are shown below.

$$\frac{N_p}{N_s} = \frac{V_p}{V_s} = \frac{I_s}{I_p}$$

The relationship above in words indicates that the Turns Ratio (N) is equal to the Voltage Ratio (V) and in turn is equal to the Reciprocal Ratio of the Current (I) (proof of these is trivial). P indicates the Primary side and S indicates the Secondary side.

For National Grid Purposes, when electricity is sent through the Overhead cables, there is a Power Loss Factor, which is equal to I^2R , where R is due to the cable. It is thus in National Grid's best interest to ensure that the current is kept low, which is why we transmit at the highest voltages possible.

2.3.1 Three Winding Transformers

The most common type of high voltage transformer used in National Grid is the three winding type, where the third (or tertiary) winding is placed on the primary side and is used for compensation equipment and harmonics.

The following diagram is a schematic of a transformer, and the photo is of one of the ___MVA Transformers at a Substation.

2.3.2 Auto Transformers

Auto Transformers are primarily used in the interconnection between 400kV and 275/132kV networks, as the transformation ratios are comparatively small. The neutral point is grounded to earth and the transformer itself is just a single winding with the secondary tapped off from this winding. Thus the High Voltage side will be the series winding, and the Low Voltage side will be the common winding. The advantages of these is that the Auto Transformer, for a given rating, is lighter and smaller, but this is somewhat offset by a lack of isolation between the two windings which could mean large overvoltages in the secondary side, if the insulation breaks down.

2.4 Earth Switches

Earth Switches are devices that connect from a bus in a Substation to ground. They are usually interlocked with a disconnecter such that they may only be opened if the disconnecter itself is open.

They are rated to carry full fault current, but only for short times only and are required to be used with Primary Earths when work is being done on equipment as part of the Electricity at Work Act. Earth Switches can also be automated – usually as part of a Gas Insulated system. They are, in principle, wholly a safety device for protecting workers when work is being carried out.

2.5 Instrument Transformers

Instrument Transformers comprise of Current Transformers, Voltage Transformers and Capacitor Voltage Transformers and are used for protection and monitoring purposes where readings from these will affect how the system behaves – for example the operation of Protection Relays.

Current Transformers can be found in up to four different positions, and have one or more of four insulation types:

Positions – Standalone, in Gas Insulated Substations, Bushings and Around Cables
Insulation types – Oil Impregnated Paper, Sulphur Hexafluoride, Cast Epoxy Resin (for Low Voltages) and Composite/fibre (optical).

Note that the primary of a CT is usually a Busbar and the secondary is set to have enough windings so that the current is $\sim 1\text{A}$ in the secondary.

It should also be noted that CTs carry a unique risk with them – a Current Transformer should NEVER be open circuited, as this could lead to dangerous levels of current induced in the secondary.

The following diagram shows a schematic of a CT and the photographs show



different CTs used by National Grid.
Picture showing a standalone Current Transformer.

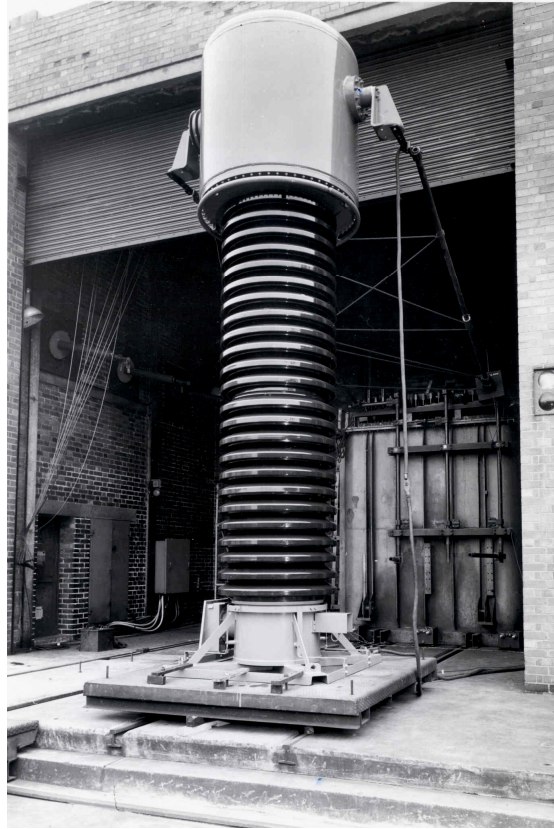

Picture Showing an SF6 Current Transformer.

Voltage Transformers are used for the same purposes as Current Transformers, for which there are mainly two types – the Wound Voltage Transformer and the Capacitance Voltage Transformer. For both types, the Voltage in the secondary should be around 110V. The wound type is similar to a transformer, which has been discussed, but the capacitance type uses capacitors, where a tap can be made at the voltage wanted. The inductance of the winding and the capacitance together constitute a circuit that could be used for filtering purposes.

The following diagrams show a schematic of a Capacitor Voltage Transformer and the photographs show how they look in a substation.

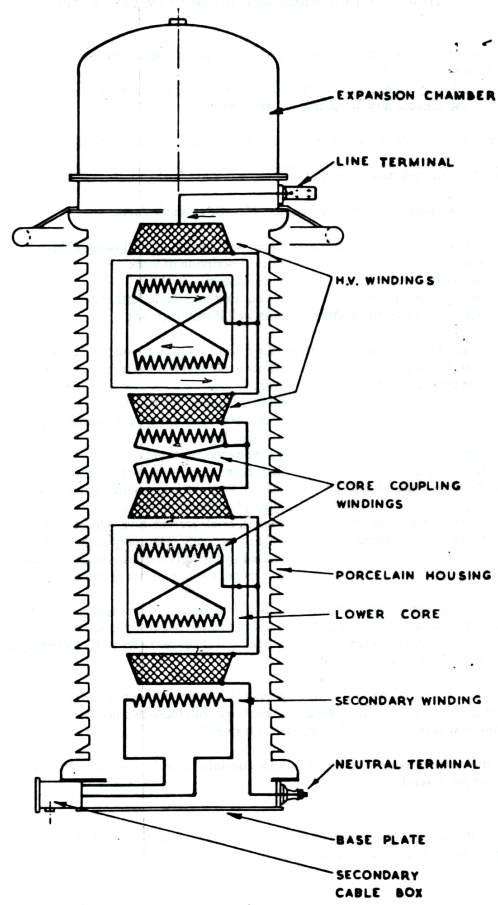

This is a schematic diagram of a Cascade Voltage Transformer.

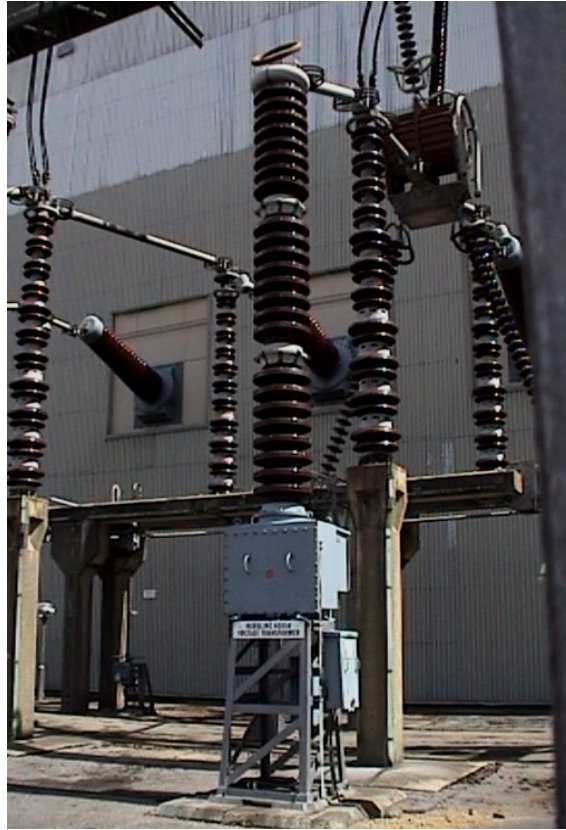

This is a photograph showing a CVT in a Substation.

CVTs were developed because of the high cost of conventional Voltage Transformers; however, their poorer frequency and transient responses offset this. The Cascade VT was developed to solve this problem. Cascade VTs are made up of several individual transformers, connected in series and each transformer has two primary windings, excepting the final transformer, where the secondary is taken off as a single winding only.

Basically, CVTs are Capacitor Potential Divider Circuit and an inductor, which is placed at the tapping point and is in series with the Capacitor, compensates the impedance (which is capacitive). Since the CVT is a series resonant circuit, resonance has to be taken into account, and thus damping should be in place to prevent this from occurring.

2.6 Busbars

Busbars form the basis of the Substation infrastructure, as it is these that Circuit Breakers, Disconnectors, Isolators etc. are all connected to. Busbar arrangement has already been mentioned in section 1 under the configurations of the Substation. Busbars are usually made from Aluminium, are hollow and positioned by Ceramic Insulators and connected to with clamps.

2.7 Cables and Cable Sealing Ends

Cables come in two very basic varieties – Overhead and Underground and therein lies the most obvious difference between the two (as well as the fact that Overhead Lines do not have any outer insulation on them). There are other factors, which need to be looked at, however.

Underground cables for High Voltages come in many forms, the most common being Oil Filled and Cross-Linked Polyethylene, which the latter has been recently developed to handle 400kV. This means that the Oil Filled cables (particularly those around London) could be replaced by these cables and would eliminate the need for oil monitoring, as there would be no oil leaks.

Cross-Linked Polyethylene cables are designed as follows: The multicore copper cable is surrounded by insulation material (Cross Linked Polyethylene), which is then covered by an Aluminium sheath and finally covered by a Polyethylene coating.

For Cable termination, we have a choice of three, dependant on the circumstances of the cable – Outdoor Termination, Gas Immersed or SF₆ and Oil Immersed. A later section will identify documentation for activities relating to Overhead Lines and Cables.

2.8 Capacitor Banks

Capacitor Banks are simply a group of Capacitors connected together in series/parallel combination and are used primarily for maintaining system voltage in strategic places throughout the country – especially places that have large inductive loads connected to them, as these must be compensated for. These banks can be large (up to 225MVAR for 275/400kV purposes) but also introduce unwanted harmonics and transients on to the system. These unwanted components may be compensated for by using Thyristor controlled Capacitors and/or Inductors, Capacitors and Resistors used in combination to produce filter circuits.

Capacitor Banks may be connected in series with Busbars, or through the tertiary winding of a transformer.

The diagram shows a schematic of a Capacitor Bank and the photograph shows one in a Substation.



Picture of a Capacitor Bank.

2.9 Synchronous Compensators

These are used to compensate for the losses generated by Synchronous Generators when absorbing or generating reactive power (which can be quite considerable compared with a Capacitor shunt arrangement).

2.10 Static Var Compensators and Relocatable Static Var Compensators (SVCs and RSVCs)

These offer advantages over standard capacitor banks as they are more easily transported to site, require less space and do not need to be connected to additional transformers. SVCs consist of Thyristors that can be used to rapidly change the phase angle of the applied voltage on the grid. They come in four different forms – TCSR (Thyristor Controlled Series Reactor), TCSC (Thyristor Controlled Series Capacitor), TSSR (Thyristor Switched Series Reactor) and TSSC (Thyristor Switched Series Capacitor).

RSVCs are also connected to the network via a tertiary winding on a transformer and provide voltage support in the event of faults. The Thyristors in these can switch in varying numbers of Capacitors as required, but do not contain reactionary branches whereas SVCs do.

2.11 Battery Systems

Batteries systems, along with Diesel Generators, provide the backup source for the Substation in the event of a failure in the LVAC system. Typical voltages are either 48 or 110V and these are permanently charged by recharging circuits that are mounted locally to the banks themselves. National Grid uses a wide range of battery types, ranging from Lead-Acid to NiCad and NiFE.

Batteries are principally used to provide power for the starting mechanisms for Diesel Generators and also provide power for services such as Emergency Lighting, Fire Protection devices, Control Systems and Intruder Alarms.

2.12 Compressed Air Systems

These systems can be found in Substations that require the use of Pressurised air, in particular those equipped with Air Blast Circuit Breakers (ABCBs). The air used is compressed and dried in order to prevent corrosion and damage to equipment, but these systems require a lot of maintenance (typically the drying agents had to be changed every two years). More modern versions use a different control system that has reduced maintenance requirements considerably. The normal arrangement of these systems is to have two compressors in duty/standby configuration and an arrangement through valves and filters to a common manifold. The typically pressures for these is approximately fourteen bar. There are two main types of Air Compressor – Rotary Screw and Centrifugal.

Some ABCBs have built in air compressors, which removes the need for such systems on site and use the air to open the breaker, relying on a spring system to close them again.

The diagram below shows a schematic of a Compressed Air System (Rotary Screw) and the photograph shows the Air Compressor System at a Substation.

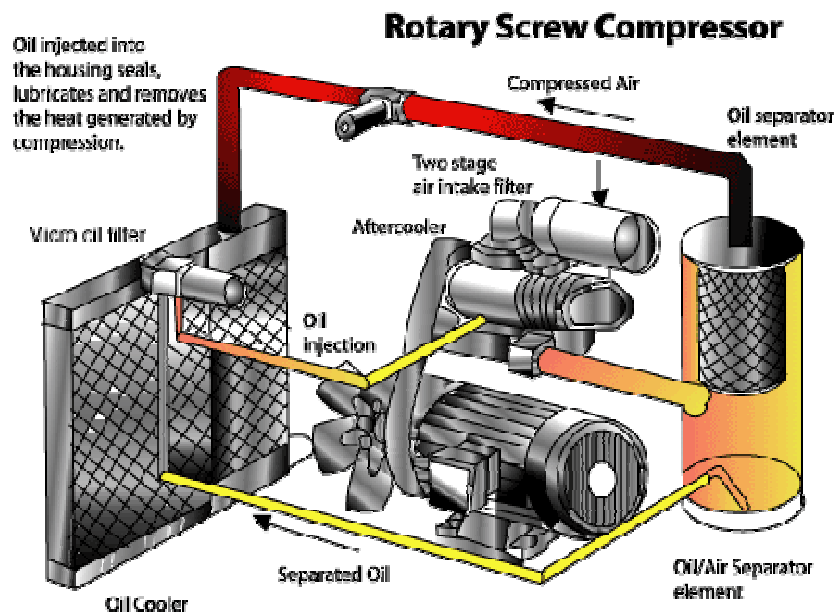

Schematic Diagram of a Rotary Screw Air Compressor System..

2.13 Diesel Generators

Diesel Generators are used as a standby, in the event that the LVAC system fails. These are usually housed on site, and are started by the battery systems described

above. The document NGTS 3.12.3 denotes all the running conditions and parameters required for the Diesel Generator and the reader is urged to consult this document for more detail regarding Diesel Generators.

Normal output for a Diesel Generator is 400V; three phase at 50Hz and supplies all the LV equipment contained within a Substation.

The photograph below shows the Diesel Generator at a Substation. The diagram is a schematic of a Diesel Generator.

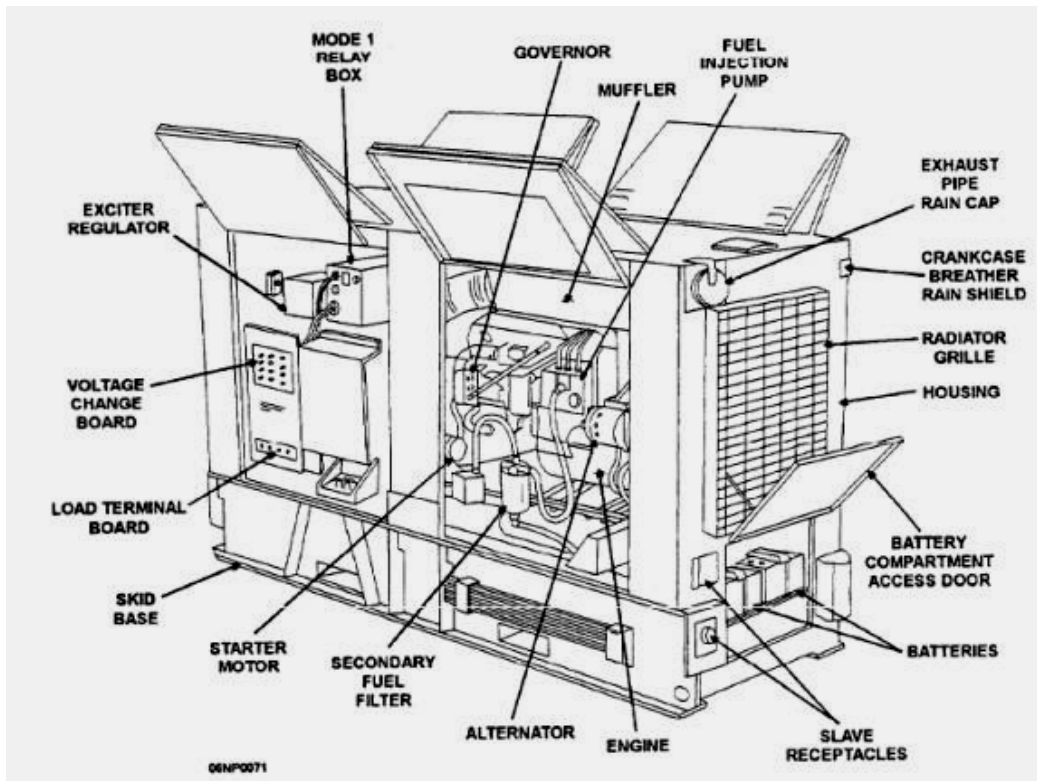

Schematic Diagram of a Diesel Generator.

2.14 Low Voltage (LV) Equipment

Low Voltage is defined as being equal to or less than 1000V according to legislation and this covers the following components:

LVAC Incoming Supplies, LVAC Boards, LVAC Loads, Diesel Generators, Compressors, Dryers, Air Boards, Receivers, Battery and Charger Systems, Battery System Loads.

All of the LV Incoming Supplies must be non-interruptible since these are essential in reinstating a Substation to a faultless state if there is unpredicted HV failure.

Dependent on the size of the Substation, the amount of LV equipment required will vary and could include components such as CB control equipment (SCADA),

Recording and Logging equipment, Tap Changing control, Fans, Oil Pumps and such like equipment.

2.15 Protection and Protection Signalling Systems

Protection systems are used for the monitoring of the system and ensuring that, in the event of a fault, the system is manipulated such to clear the fault in the shortest possible time.

Protection equipment must be able to isolate only the parts of the network that are subject to a fault and act to either clear or removed the fault from the system before allowing the part of the network to be reconnected. They must also be sensitive enough to operate when limits have been breached and also act quick enough to keep the time that fault currents are flowing to a minimum. Furthermore, all of this must be achieved within a financial premium, meaning that the best, most comprehensive protection systems might not be viable.

There are two main basic components of the protection scheme and these are the Current Transformers and Voltage Transformers mentioned previously. The positioning and methods of the connections of these components directly affect the protection that the system can be given.

Certain relays (such as Over Current Relays) have a directional property that can detect where the fault is coming from and thus trip the appropriate relay. It should be mentioned at this point that these relays require a voltage input also and this could cause problems in some protection schemes. Critical to the operation of protective devices are the time delays due to CB action and/or time delays in relay operation and these must be set carefully by a Protection Engineer to ensure that the correct relays operate at the correct time in the correct place to avoid large portions of the system from tripping out unnecessarily. Relays are also responsible for ensuring protection of the network beyond the confines of the Substation fences (see Overhead Lines and Overhead Line Protection, later in this document).

There are also backup systems, in the event that the main protection fails, and this is more heavy handed, with operating times slower than the main and also tripping out larger portions of the network than the main protection. Both the Main and Backup Protections use the same Current and Voltage transformers.

Transformers have some unique protection devices, notably Oil Level detection, Over Temperature and Over Current faults via Buchholz Relays along with differential current protection due to imbalanced loads.

2.16 Substation Control Systems

There are two control Philosophies regarding Substation Control Systems are they are SICAP and NICAP (Substation Information Control And Protection and National Integrated Control And Protection respectively).

The idea of SICAP is to have better data access, integrate Control and Protection better and improve the telecontrol functions. This is more hands on, with direct communication with the systems and with the Operations and Control Centre (done by a radio link). Other advantages include improved asset management, reduction in installation costs and maintenance complexity and avoiding development of non-standard equipment.

NICAP uses the idea of a standard Control and Protection model that is applied to all Substations across the country.

There are three Companies that National Grid use for Substation Control Systems – GEC Alstom (Space 2000 v2), Intern Computer Systems (D200SCS (SPARK 2)) and Siemens (SINAULT LSA 678 v7). Details of these systems can be found in the records rooms of the Substations that use these Control Systems

3. Nomenclature and its purpose in National Grid

Nomenclature is very important in National Grid to identify key components such as Busbars, Disconnectors, Circuit Breakers etc. that are used in the Grid. Each component has its own unique identification, using a complex system of letters and numbers to ensure that no mistakes are made when identifying a piece of equipment that may be worked on. In addition to this, each Substation is uniquely identified so as to not cause confusion when many similar pieces of equipment are to be worked on at different locations.

The details of Nomenclature can be found in Transmission Procedures Document 109 (TP109) and the reader is encouraged to read this article as reproduction here would be onerous.

An example of a circuit diagram with nomenclature added is shown on the next page.

400kV FOUR CIRCUIT BREAKER MESH

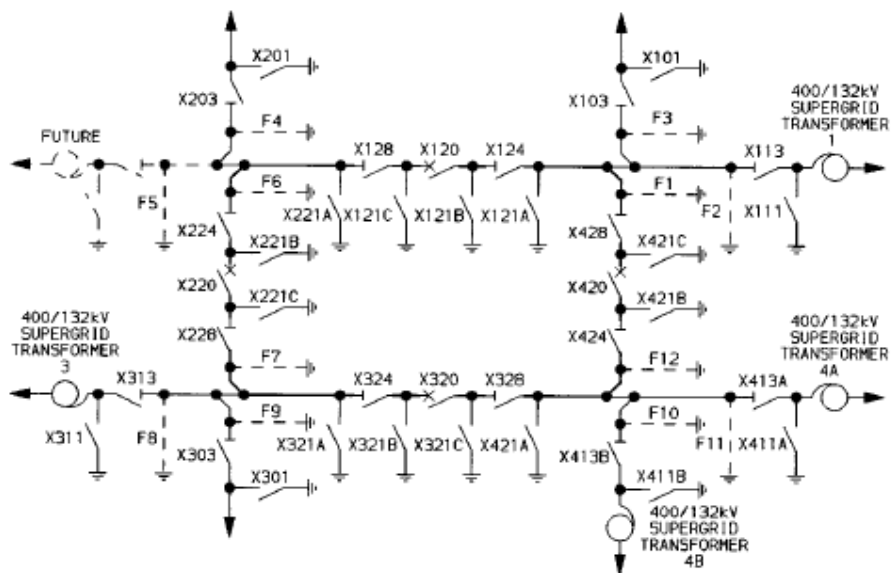

275kV FOUR CIRCUIT BREAKER MESH WITH MESH OPENING CORNER DISCONNECTORS

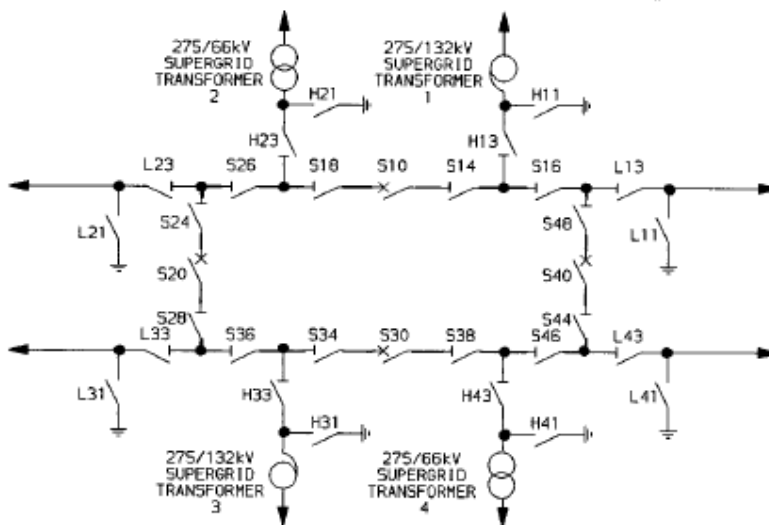

NUMBERING AND NOMENCLATURE OF 400kV AND 275kV MESH SUBSTATIONS

Schematic Diagram showing the nomenclature of 400kV and 275kV Substations.

4. Overhead Lines and Cables

This section will identify the documents and procedures used when National Grid are to conduct activities relevant to dealing with Overhead Lines and Cables.

Such activities include (but not restricted to) Tree Cutting, Overhead Conductor Repair, EMIs (Equipment Modification Instructions), Overhead Line Ratings and Downratings, Live Line Working and Route Identification. Protection will also be examined.

For National Grid Overhead Lines, the preferred conductor is the AAAC Conductor (All Aluminium Alloy Conductor) although ACSR (Aluminium Conductor Steel Reinforced) conductors are used, along with the 'Matthew' GZTACSR (Gap Type ZT Alloy Conductor Steel Reinforced) and the 'Keziah' AACSR or the OPGW (Optical Ground Wire), for 132kV, High Temperatures and Earthing respectively.

The following table shows the preferred bundle of cables for a particular situation:

Tower Design	Bundle Designation	Conductor System	Nominal Rated Temperature °C.
L4 132kV	L4 (M)	1 x 175mm ² ACSR	50
L7 132kV	L7(C)	2 x 175mm ² ACSR	50
L3 275kV	L3/1	1 x 700mm ² AAAC	50
	L3/2	2 x 300mm ² AAAC	50
L66 275kV	L66/1	1 x 700mm ² AAAC	50
	L66/2	2 x 300mm ² AAAC	50
L2 400kV	L2/2	2 x 500mm ² AAAC	75
	L2/6	2 x 620mm ² GZTACSR	170
	L2/4	2 x 570mm ² AAAC	75
L8 400kV	L8/2	2 x 500mm ² AAAC	75
	L8/6	2 x 620mm ² GZTACSR	170
	L8/4	2 x 570mm ² AAAC	75
L6 400kV	L6/2	2 x 700mm ² AAAC	75
	L6/3	2 x 500mm ² AAAC	75
	L6/4	2 x 850mm ² AAAC	75
	L6/5	3 x 700mm ² AAAC	50
L12 400kV	L12	2 x 700mm ² AAAC	75
	L12/1	2 x 850mm ² AAAC	75

This table shows the preferred Conductor Bundles for NGT Overhead Towers.

4.1 Activities involving Overhead Lines and Cables

The following list shows the relevant NGT Documentation concerning procedures and safety for the activities mentioned above:

1. Tree Cutting. The document concerning this activity is the Forestry and Arboriculture Document (Ref: Safety UK BP/SE/311)

2. Overhead Line Conductor Repair. Documents and references to further documents can be found in Technical Guidance note TNG(AH) 4. In fact this document is the most comprehensive of all the documents referring to Overhead Lines and readers are encouraged to read this anyway.
3. EMI (Equipment Modification Instructions). These were formerly known as TDCs and the following EMIs refer to Overhead lines and Towers:
 - a. EMI 501 (Replacement of Dowel Pins)
 - b. EMI 850 (Replacement of Quad Spacers)
 - c. EMI 898 (Testing and Replacement of Porcelain Insulators)
 - d. EMI 863 (Modifications to Parallel sided extensions of L2 Towers)
 - e. EMI 872 (Modifications to Particular bracings of selected L8c Towers)
 - f. EMI 925 (Modifications to selected bracings of JL EVE L6 Towers)
4. Overhead line Ratings and Downratings. Technical Guidance Note TGN (E) 26 contains the specifics for Current ratings for Overhead Lines. Downrating can occur in cables due to damage or faults which means that the line cannot operate at full capacity – the net result being that the cable is till used at a lower rating. In the event of Overhead Line Damage, TP156 should be used.
5. Live Line Working. Article TP134 contains the procedures dealing with working on/near Live Overhead Lines.
6. Route Identification.

4.2 Protection and Overhead Lines

Protection for Overhead Lines differs from normal protection in that adjacent Substations must be in constant communication with each other, whereas as for other protection, the need for communication with other Substations is perhaps not so great.

With Overhead Lines where the distance between points of contact (the Substations) is not insignificant, a scheme called Power Line Communications (PLCC) may be used which utilises the lines themselves for the communications. The signals are high frequency and High Voltage Capacitors are used to inject the signal and extract it from the line. This is so the signal does not interfere in any way with the actual transmission of Electrical Power itself. Line or Wave traps can be used to ensure that the losses in the signal sent/received are minimised.

Alternative arrangements for signals could be through radio links (costly and shorter range) or through Optic Fibre cables (which is probably the future).

For the protection itself, there are two main forms – unit and distance protection. The details of these can be found in any Power Systems Protection text, but a particularly good one is Network Protection and Automation, published by Alstom. Chapters 10, 11 and 12 are particularly useful to the reader on this subject. To simplify the process greatly, however, Protection is handled mainly by relays.

The following table showing a selection of the relays available:

Fault Location (Distance to Fault)
Instantaneous Overcurrent Protection
CT Supervision
Auto-reclose
CB State and Control
Event Recorder
Negative Sequence Protection
Under/Overvoltage Protection

This is a table adapted from Network Protection and Automation.

5. Safety Systems Overview

All persons working with and/or for National Grid Transco should be aware of the following acts and regulations, and comply with them fully. For more details, readers are urged to consult the relevant document(s).

Electricity at Work Act

Health and Safety at Work Act

Pressure Systems Safety Regulations

Management of Health and Safety at Work Act

National Grid Safety Rules and National Safety Instructions (NSI)

These documents may refer to Persons, Authorised Persons, Senior Authorised Persons and so on. The definitions for the different categories are as follows:

Personnel under the terms of National Grid may be one of the following:

- a. Person – An individual with sufficient technical knowledge or experience to avoid danger
- b. Competent Person – A Person who has been appointed by an appropriate officer of the company, or other companies, to be responsible for the operational control and co-ordination of the system within and across defined boundaries. He can also transfer temporary control of a part of the HV system using a System State Certificate
- c. Authorised Person – A Person who has been appointed by an appropriate officer of the company to carry out specified duties in writing.
- d. Senior Authorised Person – A Person who has been appointed by an appropriate officer of the company to carry out specified duties in writing, including the preparation, issue, transfer and cancellation of specified safety documents.
- e. Control Person – being one of the following:
 - i. Control Person (Operation) – A Person who has been appointed by an appropriate officer of the Company, or other Companies, to be responsible for the operational control and co-ordination of the system within and across defined boundaries. He can also transfer temporary control of a part of the HV system using a System State Certificate.
 - ii. Control Person (Safety) – A Person who has been appointed by an appropriate officer of the Company, or other Companies, to be responsible for controlling and co-ordinating safety activities necessary to achieve safety from the system within and across defined boundaries. He can also receive temporary control of part of the HV system using a System State Certificate.

5.1 Electricity at Work Regulations

These Regulations are primarily directed at installations/hardware requirements. This includes issues such as installation construction, insulation, isolation etc. The regulations also state principles of safe working practice.

The following table is a list of some of the Regulations:

Regulation
Interpretation
Duties
Systems, Work Activities and Protective Equipment
Strength and Capability of Electrical Equipment
Adverse or Hazardous Environments
Insulation, Protection and Placing of Conductors
Earthing and other suitable Precautions
Integrity of Reference Conductors
Connections
Means for Protecting from Excess Current
Means of Cutting off Supply and for Isolation
Precautions for work on Equipment made Dead
Work on, or near Live Conductors
Working Space, Access and Lighting
Competence to Prevent Danger and Injury
Defence
Exemptions
Disapplication of Duties

5.2 Health and Safety at Work Act

This is the main legislation (also known as an umbrella act as it encompasses many areas) that governs health and safety and promotes good safety management at work. The main aims of the act are to

1. Secure the health, safety and welfare of people at work.
2. Protect other people against risks arising from work.

The key sentence in this is that “It shall be the duty of every employer to ensure, so far as is reasonable practicable, the health, safety and welfare at work of all his employees”

This general duty is broken down into four key areas, which are detailed in HSG65 – Premises, Plant and Substances, Procedures and People.

5.3 Pressure Systems Safety Regulations

These regulations deal with safety regarding pressure systems (e.g. Compressed Air Systems). The HSE Website contains all the information needed on these regulations. Note that these regulations do not cover Gas Cylinders.

5.4 Management of Health and Safety at Work Regulations

These regulations cover aspects such as Risk Assessments, Health and Safety Arrangements, Training, Employee's Duties and so on. These are designed to work with the Health and Safety at Work Act and provide a safer workplace for all.

All of the information regarding any of the Regulations and Acts can be found on either the HSE Website, or the Office of Public Sector Information (www.opsi.gov.uk).

5.5 National Grid Safety Rules and NSI Overview

The following table lists all of the NSIs available on the Intranet and are additional safety instructions for specific tasks that are carried out within National Grid. In order to become a Competent Person, each NSI has to be assessed both theoretically and in practice. NSI 0 is simply an index NSI that produced this list.

NSI 0	Explanatory Notes and Index
NSI 1	Operational and Safety Switching
NSI 2	Earthing High Voltage Equipment
NSI 3	High Voltage Metalclad Switchgear with Spouts
NSI 4	Work on or Near High Voltage Overhead Lines (Available in A4 only, Limited Circulation)
NSI 5	Cable Systems
NSI 6	Work and Demarcation in Substations
NSI 7	Access to High Voltage Compartments and Structures
NSI 8	Mobile Elevated Work Platforms, Lorry Loaders, Vehicles, Cranes and Long Objects in Substations
NSI 9	Testing High Voltage Equipment
NSI 10	Equipment Containing Sulphur Hexafluoride (SF6)
NSI 11	High Voltage Static Capacitor Banks
NSI 12	Low Voltage Equipment
NSI 13	Washing High Voltage Insulators

- NSI 14 Automatically or Remotely Controlled Equipment
- NSI 15 Brush Gear of High Voltage Rotating Machines
- NSI 16 High Voltage Overhead Lines, Work on Towers and Earthwires
- NSI 17 Pressure Systems
- NSI 18 Hydrogen Filled Machines
- NSI 19 Overhead Travelling Cranes
- NSI 20 Fire Protection Areas
- NSI 21 General Confined Spaces
- NSI 22 Cable Tunnels and Culverts
- NSI 23 Unused
- NSI 24 Earth Systems
- NSI 25 Procedure for Precautions to enable Safe Working on Overhead Towers with Microwave/Radiowave Aerial Installations
- NSI 26 Unused
- NSI 27 Unused
- NSI 28 Unused
- NSI 29 Unused
- NSI 30 Appointment of Persons (NGC Safety Rules)
- NSI 31 Approval Procedure
- NSI 32 Register of Approvals
- NSI 33 The Addition/Removal of Equipment To/From the System